



Certificate of Accreditation

Sewage Management Facility

Aerated Wastewater Treatment System

Advanced Secondary Effluent

This Certificate of Accreditation is issued by the Secretary of the NSW Ministry of Health pursuant to Clause 41(1) of the Local Government (General) Regulation 2005.

System: "Rivatec RWT10" Advanced Secondary AWTS

Manufacturer: Rivatec Environmental Pty Ltd

Address: 6 Marklea Close, Tuggerah, NSW, 2259

The "Rivatec RWT10" Advanced STS-AWTS as described in Schedule A, has been Accredited as a sewage management facility in accordance with the Secondary Treatment System Accreditation Guideline 2018 for use in single domestic premises in NSW. This Accreditation is subject to the conditions and permitted uses specified in Schedule B.

*Director, Environmental Health
for Secretary (delegation PH335)*

Issued: 19 November 2019

Certificate No: STS-AWTS040

Expires: 31 December 2024

Schedule A: Specification / Description of the Advanced STS

Name and Model of STS: Rivatec Environmental "Rivatec RWT10"

The Rivatec RWT10 is designed to treat sewage from a residential dwelling occupied by a maximum of 10 persons. The Rivatec RWT is contained in a collection well with design capacity of 7100 L. NSW Health Accreditation Number STCW015.

Chamber	Design capacities
Primary treatment with buffer chamber	3100 L
• Partition	yes
Secondary treatment	3545 L
• Aeration chamber	2650 L
• Clarifier	565 L
• Irrigation chamber	165 L
Emergency storage	1660 L
Operational water level (depth)	(mm)
• primary	1520 to 1750
• secondary	1700

The emergency storage capacity is achieved by a varied air gap above the working effluent level 550mm to 400mm to the top of the chambers.

The Rivatec RWT10 is contained in one concrete tank having the following components:

- Primary treatment chambers into which sewage from the dwelling flows where a physical separation of foreign material such as fat, grease and scum occurs and allows for a reduction in BOD and TSS concentrations. Effluent is transferred by air lift in the primary buffer chamber to a second primary chamber with floating media.
- Aeration chamber – Primary treated wastewater flows into the aeration chamber where aeration is cycled 12 hrs ON/ 12 hrs OFF to assist denitrification of the nitrogen oxides in the wastewater. The floating media in the chamber provides a surface area for the growth of bacteria to allow for the bio-degradation of organic material in the wastewater.
- Clarifier – Treated wastewater is transferred into the clarifier allowing for the removal of settled solids. The solids are transferred to the primary treatment tank by way of an airlift device which is activated for 1 minute every 2 hours.
- Disinfection – A chlorine disinfection unit is installed on the outlet of the clarifier and discharges into the irrigation chamber for contact disinfection.
- Irrigation Chamber – Receives and stores final advanced treated effluent for pumping to the designated disposal area.
- Air Supply – Air is supplied to the contact aeration chamber by a HP120 air blower or equivalent, producing an airflow of a nominal 120 litres/minute at 1.7 m water depth. The air is distributed via a manifold to three aeration legs located near the base of the aeration chamber and two airlift devices located in the aerobic zone and in the clarifier. The two airlift devices continually return partially treated wastewater and settled solids to the inlet of the primary treatment tank.
- A Bianco Pumpz model BIA-B42AC submersible irrigation pump or equivalent is installed in the irrigation chamber.
- Alarm System

Schedule B: Conditions of Accreditation

1. General

- 1.1 Prior to installation the owner/occupier of the premises shall make an application, in accordance with Clause 26 of the *Local Government (General) Regulation 2005*, to the local authority for approval to install and operate the Rivatec RWT10 as a Sewage Management Facility in accordance with Section 68, Part C of the *Local Government Act 1993*.

- 1.2 The local authority shall apply those Conditions of Accreditation, appropriate to the owner / occupier, to any approval to operate the Rivatec RWT10 issued under Clause 45(4), *Local Government (General) Regulation 2005*.
- 1.3 In accordance with Clause 36 of the *Local Government (General) Regulation 2005*, the Rivatec RWT10 shall have an expected service life of 5 years in the case of mechanical and electrical components and 15 years in the case of other components.
- 1.4 The owner / occupier shall ensure that the Rivatec RWT10 is installed or constructed:
- in accordance with the accredited specifications of the type tested unit and in accordance with good trade practice, and
 - so as to allow ease of access for maintenance, and
 - with regard to the health and safety of users, operators and persons maintaining the facility, and
 - must be installed or constructed so as to make appropriate provision for access to and removal of contents in a safe and sanitary manner, and
 - must, if it is intended to be a permanent fixture, be anchored to prevent movement.
- 1.5 The manufacturer / supplier shall ensure that the Rivatec RWT10 is supplied, constructed and installed in accordance with the design (including the disinfection unit) as submitted and accredited by the NSW Ministry of Health. The Rivatec RWT10 shall not be modified or altered except that alternate individual mechanical and electrical components such as pumps, PLCs, etc., may be substituted provided that the component meets the Accredited design specification.
- 1.6 Any permanent modification or variations to the accredited design of the Rivatec RWT10 shall be submitted for separate consideration and variation of the Certificate of Accreditation by the NSW Ministry of Health. Modifications will be considered in accordance with section 2.3.13 of AS1546.3:2017.
- 1.7 Each Rivatec RWT10 shall be permanently and legibly marked by the manufacturer in accordance with section 3 of AS1546.3:2017.
- 1.8 The manufacturer shall supply with each Rivatec RWT10 an owner's manual, which sets out the care, operation, maintenance and on-going management requirements of the system. The owner's manual prepared by the manufacturer shall specifically contain a plan for the on-going management of the Rivatec RWT10. The plan shall include details of:
- the treatment process,
 - procedures to be followed in the event of a system failure,
 - emergency contact numbers,
 - maintenance requirements,
 - inspection and sampling procedures to be followed as part of any on-going monitoring program developed by the local authority.
- 1.9 The manufacturer shall provide the following information to each local authority where it is intended to install a Rivatec RWT10 in their area once accreditation has been obtained:
- | | |
|-----------------------------------|--------------------------------------|
| • Statement of warranty | • Manufacturer's Service Report Form |
| • Statement of service life | • Engineering Drawings |
| • Quality Assurance Certification | • Specifications |
| • Installation Manual | • A4 Plans |
| • Service Manual | • Certificate of Accreditation |
| • Owner's Manual | documentation from NSW Health. |
- The manufacturer need not provide the above information to the local authority where the information or document is contained on the manufacturer's web site.

2. Installation and Commissioning

- 2.1 The owner / occupier shall have the Rivatec RWT10 inspected and checked by the manufacturer or the manufacturer's agent. The manufacturer or the agent is to certify that the system has been installed and commissioned in accordance with its design, conditions of accreditation and any additional requirements of the local authority.

- 2.2 The owner / occupier shall ensure that all electrical work is carried out on the Rivatec RWT10 by a licensed electrician and in accordance with the relevant provisions of AS/NZS 3000.
- 2.3 The owner / occupier shall not commission the Rivatec RWT10 unless the land application system has been completed.

3. Maintenance

- 3.1 The owner / occupier of the premises shall enter into a minimum 12 month contract or agreement with a service agent and ensure that the Rivatec RWT10 is serviced:
- in accordance with the manufacturer's / supplier's service manual and using the manufacturer's / supplier's service sheet; and
 - by a service agent who
 - has completed a course on the servicing and maintenance of STS; and has some supervised servicing experience or extensive un-supervised experience;
 - is employed or authorised by the manufacturer / supplier of the Rivatec RWT10;
 - uses replacement parts which meet the minimum specification of the Rivatec RWT10;
 - has advised of their name, contact details and credentials to the local authority;
 - submits a completed NSW Health "Local Council Service Report" (attached) to the local authority immediately after each and every service;
 - shall report to the local authority any instances where the owner / occupier refuses to authorise repairs, replacement of parts or maintenance; and
 - does not perform electrical work or enter confined spaces unless trained and is suitably qualified to do so.
- 3.2 The owner/occupier shall not service the Rivatec RWT10 unless they are an authorised agent.
- 3.3 The Rivatec RWT10 once installed and commissioned shall be serviced at 3 monthly intervals.
- 3.4 The manufacturer / supplier of the Rivatec RWT10 shall place on its web site a copy of the service manual, service sheet or form and specifications for the Rivatec RWT10 to facilitate servicing, maintenance and repairs. Commercial-in-confidence documents may be provided directly to the service agent without uploading to the web site.
- 3.5 Each three monthly service shall, as a minimum where provided, include a check on all mechanical, electrical and functioning parts of the system including:
- The chlorinator and replenishment of the disinfectant,
 - Any alternative disinfection unit,
 - Replace a UV light globe at recommended intervals and keep a record,
 - Pump and air blower,
 - The alarm system,
 - Slime growth on the filter media,
 - Operation of the sludge return system,
 - The effluent irrigation area,
 - On-site testing for free residual chlorine, pH and dissolved oxygen at the appropriate check points.

4. Verification

- 4.1 Effluent from the Rivatec RWT10 taken in any random grab sample shall comply with the following standard:
- BOD⁵ less than 30 mg/L
 - TSS less than 45 mg/L
 - E. coli less than 100 cfu/100 ml
 - Free residual chlorine greater than 0.2 and less than 2.0 mg/L

5. Permitted uses

- 5.1 The effluent is suitable for re-use for garden purposes by way of any of the forms of irrigation as described in AS/NZS 1547:2012:
- above ground spray irrigation; and/or
 - surface drip irrigation covered by mulch; and/or
 - sub-surface drip irrigation installed at around 100 mm depth; and or

- any form of sub-soil application.

Each of the forms of irrigation or application is subject to the approval of the local authority.

6. Advanced Secondary Treatment System

- 6.1 The Rivatec RWT10 when tested by a Product Certification Body in accordance with AS1546.3:2017 was found to comply with the Advanced Secondary Effluent Criteria as follows:

**TABLE 2.1 (Abrev) AS1546.3:2017
ADVANCED SECONDARY EFFLUENT COMPLIANCE CRITERIA FOR A STS**

Parameter	Advanced secondary effluent	
	90% of Samples	Maximum
BOD5	≤ 10mg/L	20 mg/L
TSS	≤ 10 mg/L	20 mg/L
<i>E. coli</i> *	≤ 10 cfu/100mL	30 cfu/100mL
FAC p	Minimum 0.5 mg/L†	N/A
Turbidity ?	N/A	10 NTU

* Where disinfection is required.

p Where chlorine disinfection is used.

† Minimum level, not 90% of samples.

? Where UV light is used for disinfection .

Local Council STS (DGTS) Service Report: February 2018		
Owner's Name:	Local Council:	
Installation Address:		
System Brand & Model:	<input type="checkbox"/> Domestic	<input type="checkbox"/> Commercial
Date of this service: / /	Date of last Service: / /	Next service due: / /
Has the STS/DGTS been serviced in accordance with the manufacturer's / supplier's requirements and using the service sheet? <input type="checkbox"/> Yes <input type="checkbox"/> No If "No" why not?		
STS/DGTS functioning correctly? <input type="checkbox"/> Yes <input type="checkbox"/> No If "No" why not?		
According to sludge-judge or other methodology is de-sludging needed? <input type="checkbox"/> Yes <input type="checkbox"/> No If "Yes" what action is recommended?		
Offensive odours?	<input type="checkbox"/> Yes <input type="checkbox"/> No	If "Yes" what action is recommended?
Alarms tested and functional?	<input type="checkbox"/> Yes <input type="checkbox"/> No	If not "functional" what action is recommended?
Final Effluent Quality		
Tested?	<input type="checkbox"/> Yes <input type="checkbox"/> No	
Disinfected?	<input type="checkbox"/> Yes <input type="checkbox"/> No	
Chlorine tablets remaining?	<input type="checkbox"/> Yes <input type="checkbox"/> No	
Quality?	<input type="checkbox"/> Satisfactory <input type="checkbox"/> Unsatisfactory	
On what evidence is this judgement made? If "Unsatisfactory" what action was recommended?		
Land Application Area		
Surface ponding?	<input type="checkbox"/> Yes <input type="checkbox"/> No	
Run off?	<input type="checkbox"/> Yes <input type="checkbox"/> No	
Excess plant growth?	<input type="checkbox"/> Yes <input type="checkbox"/> No	
Effluent leaving premises?	<input type="checkbox"/> Yes <input type="checkbox"/> No	
High risk areas contaminated?*	<input type="checkbox"/> Yes <input type="checkbox"/> No	* Patio, play areas, BBQ, etc
Operating satisfactorily?	<input type="checkbox"/> Yes <input type="checkbox"/> No	If "Not operating satisfactorily" what action was recommended?
Overall Condition of STS? <input type="checkbox"/> Excellent <input type="checkbox"/> Good <input type="checkbox"/> Fair <input type="checkbox"/> Poor		
Comments / Action Recommended / Repairs Needed / Repairs Performed:		
Has the owner / occupier taken recommended actions? <input type="checkbox"/> Yes <input type="checkbox"/> No		
Service Agent:	Contact Details:	
Signature:	Date:	

Source: Adapted from "Checklist 4.2: Operational AWTS inspection report for use by service providers and Council inspectors" in *Designing and Installing On-Site Wastewater Systems*, Sydney Catchment Authority, May 2012



Rivatec Environmental

ABN; 19 099 003 737
 PO Box 605 Wyong 2259
 6 Marklea Close Tuggerah 2259
 Ph; 1300 327 847

email; steven@rivatec.com.au
rivatecenvironmental.com.au

Designed; SF
 Lic;339816C

Date;

Site;

RWT10

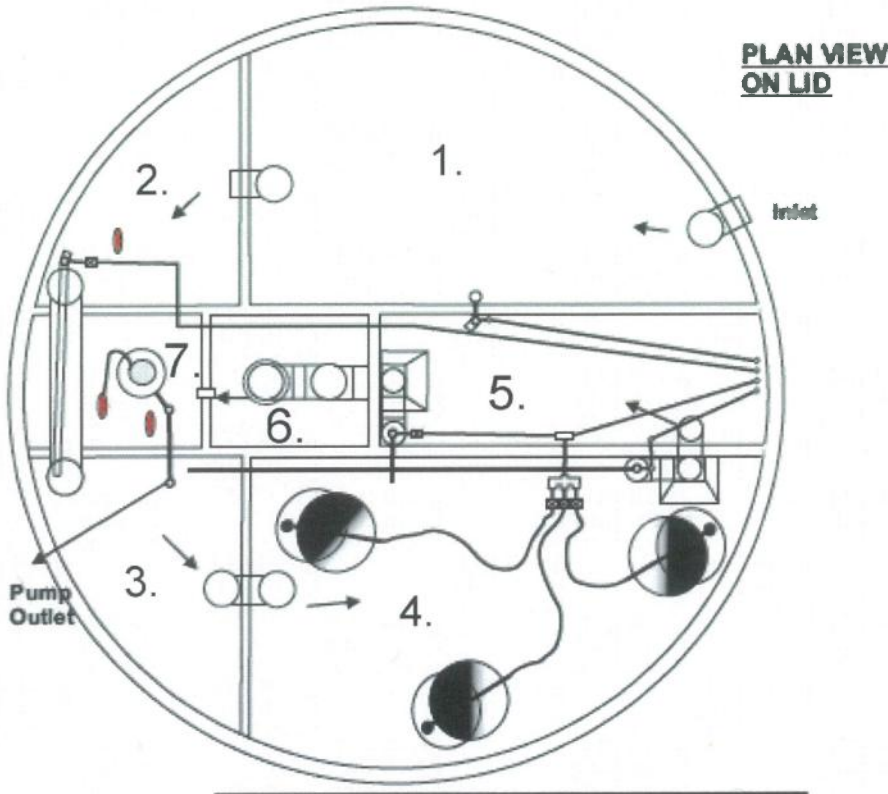

Legend;

- 1. 2/3 Primary
- 2. Buffer Primary
- 3. 1/3 Primary
3100 litres
- 4. Aeration
2650 litres
- 5. Clarifier
565 litres
- 6. Disinfection
165 litres
- 7. Irrigation
165 litres

ACCREDITED

19 NOV 2019

NSW MINISTRY OF HEALTH

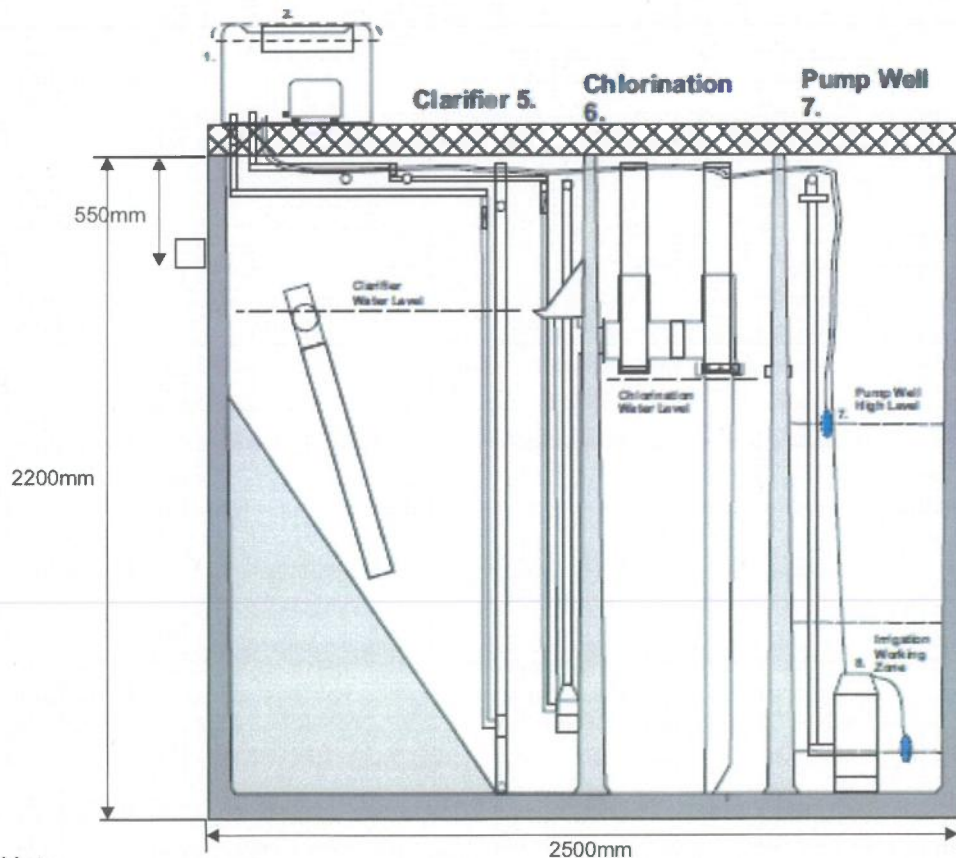

Hole Excavation

**Depth - 2200mm
 Width - 3000mm²**

Note;
 All Tanks To Comply With AS/NZ 1546.1 - All PVC Fittings To Comply With AS/NZ 1477
 System Designed By RIVATEC ENVIRONMENTAL PTY LTD
 Tank Manufacture;
 Central Coast Septics